

# HA 700

EN

## Air purifier

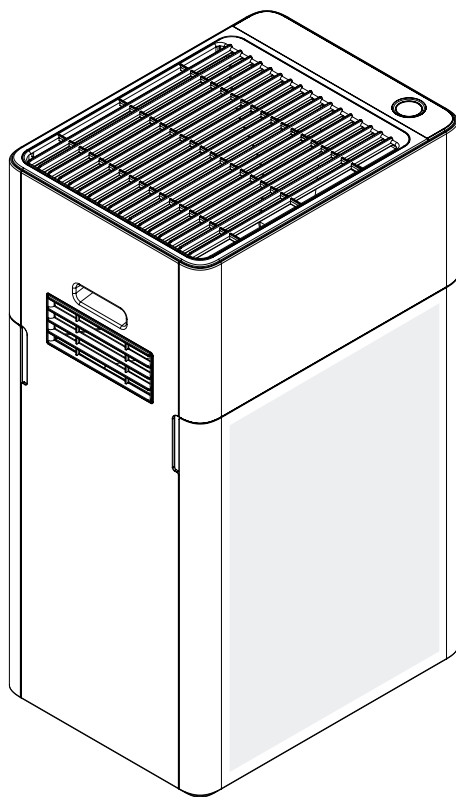

*User manual*

# horizon

A I R P U R I F I E R



# HA 700

## Air purifier

### INDEX

<b>1</b>	Precautions	<b>4</b>
<b>2</b>	Name of each part	<b>11</b>
<b>3</b>	Characteristic	<b>12</b>
<b>4</b>	Control/signs	<b>13</b>
<b>5</b>	User instruction	<b>14</b>
<b>6</b>	How to replace the filter	<b>17</b>
<b>7</b>	How to clean pre-filter	<b>19</b>
<b>8</b>	Solution to common problems	<b>20</b>
<b>9</b>	Specifications	<b>21</b>
<b>10</b>	Warranty	<b>22</b>

Order to safely and use rightfully please read this manual carefully. Please keep this manual {Product warranty is included}.

horizon

A I R P U R I F I E R

# 1. PRECAUTIONS

Read carefully following precautions to prevent unpredictable dangers and damages.



**DANGER:** If not observed, serious injury or even death could occur.

**WARNING:** If not observed, Slight injury of property damage could occur.

**CAUTION:** If not observed, Slight injury of property damage could occur.

## PRECAUTIONS FOR POWER SUPPLY



**1.** This product must be plugged into AC220V outlet.

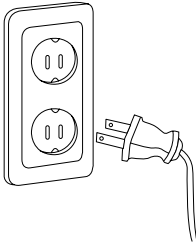

\* It could cause a fire or electric shock.



**2.** Before use, please wipe dust or other foreign substances off on the plug.



\* It could cause a fire or electric shock.



**3.** Please do not use when the plug is damaged or swinging.

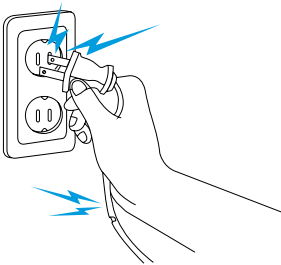

\* It could cause a fire or electric shock.

\* When the plug is damaged, contact customer service center or your purchasing place.



**4.** Before replacing filter, please unplug the power cord.

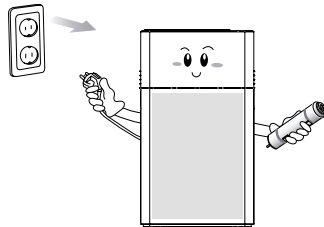

\* It could cause electric shock.

## PRECAUTIONS FOR POWER SUPPLY



**5.** Please do not try to bend, tie or pull the power cord.

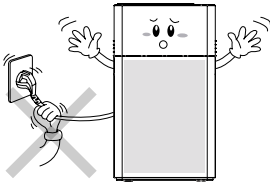

\* It could cause a fire by electric shock.



**6.** The outlet should be rated for more than 16A. Use a separate outlet for the unit.

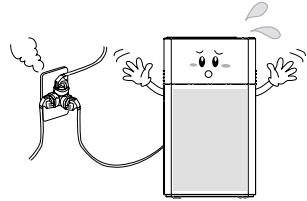

\* Do not plug too many cords into the outlet. It could cause a fire.



**7.** Please do not disassemble or modify the plug.

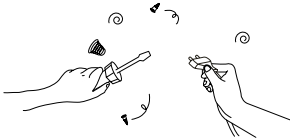

\* It could cause a fire or electric shock.



**8.** Please do not plug in or unplug the power cord with wet hands.

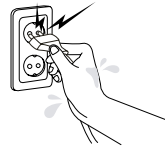

\* It could cause electric shock.



**9.** Please do not unplug the unit by pulling out its power cord.



\* It could cause a fire or electric shock



**10.** Do not severely bend the power cord or put heavy object on it.

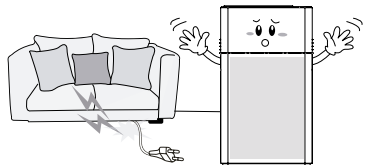

\* It could cause a fire.

# PRECAUTIONS FOR INSTALLATION



**1. Avoid heat and direct sunlight.**

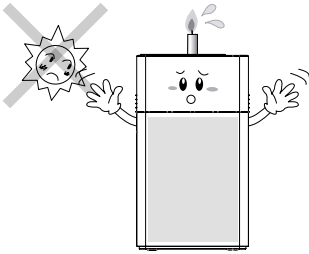

\* It could cause deformation of the exterior.



**2. Do not place the unit on an unstable or sloped surface.**

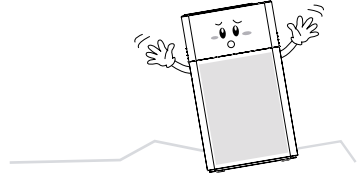

\* It could cause malfunction.



**3. Do not place the unit near inflammable materials.**

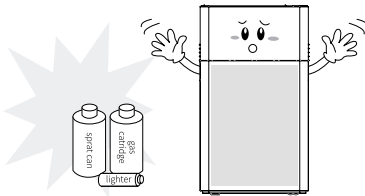

\* It could cause an explosion and fire.



**4. Please do not install the unit at a moist place like bathhouse, shower room or swimming pool.**

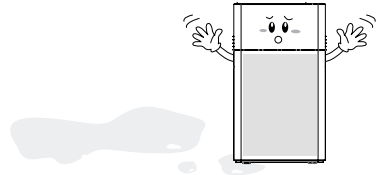

\* It could an electric shock or fire.



**5. Do not disassemble, repair or modify by yourself.**

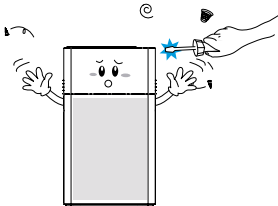

\* It could an electric shock or fire.



**6. Maintain a sufficient distance from inflammable materials. At least 40 inches is recommended.**

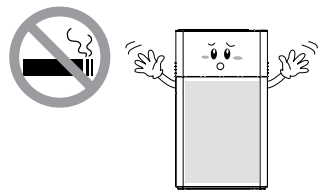

## PRECAUTIONS FOR INSTALLATION



**7.** Do not insert a sharp wire and screwdriver into the unit inside.

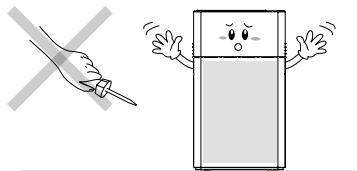

\* It could cause electric shock or malfunction.



**8.** Do not touch the interior of the product with wet hands.

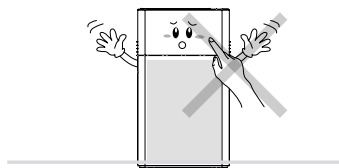

\* It could cause electric shock.



**9.** Do not apply severe impacts to the unit.

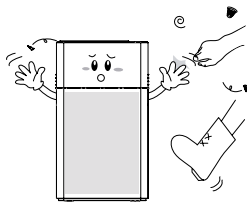

\* It could cause malfunction, damage or electric shock.



**10.** Do not move the unit while it is being operated.

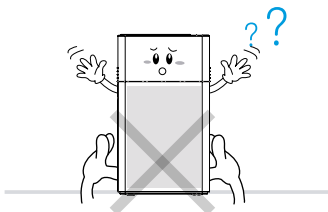

\* It could cause malfunction.



**11.** Do not put heavy stuff on the unit.



\* It could cause damage to the unit.



**12.** Do not spray pesticide or flammable liquids.

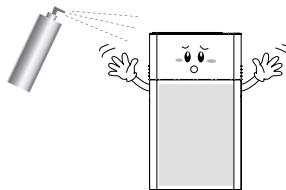

\* It could cause a malfunction.

## PRECAUTIONS FOR USE



**1. Do not operate the unit without filters.**

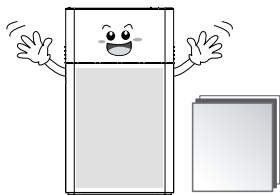

\* It could cause electric shock and product life cycle reduction.



**2. Cover the unit when it is not in use for a long time.**

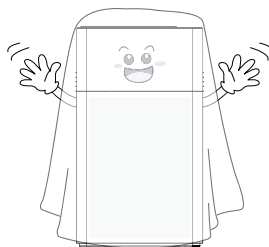

\* It could cause malfunction.



**3. Do not use the unit in greasy or dusty places such as restaurants, kitchens or construction site.**

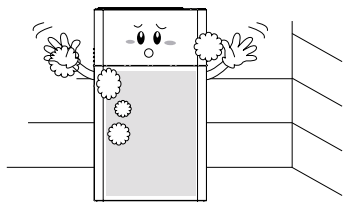

\* It could cause contamination of sensor and shortening of filter lifetime.



**4. Do not use the unit in a place that has much of toxic gases.**

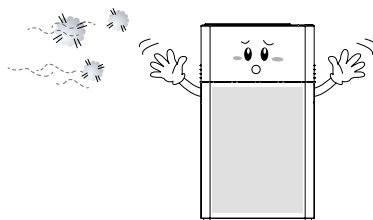

\* It could cause malfunction.



**5. Do not use the unit in extremely cold or hot place.**

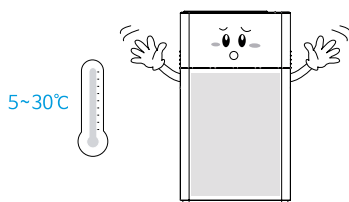

\* Optimum temperature for use is between 5°C and 30°C.



**6. Do not spray the unit with water.**

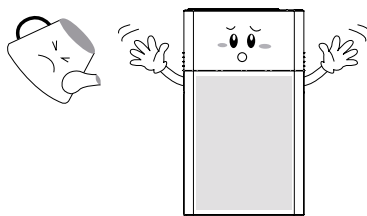

\* It could cause electric shock or malfunction.



## PRECAUTIONS FOR USE



**7.** Do not insert anything into the air inlet or outlet.

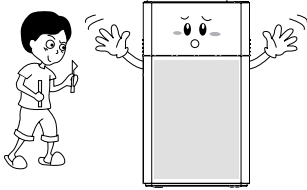

\* Especially it requires attention for children.  
It could cause burns, electric shock and failure.



**8.** Stop using the unit if any irregular noise or smoke occurs.

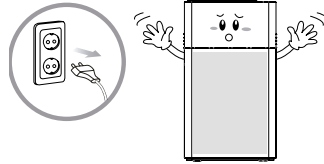

\* Pull out the plug and then call the customer service center.



**9.** Do not block the air inlet or outlet.

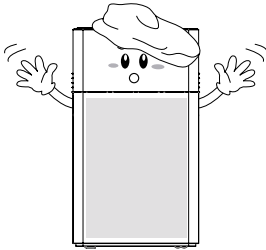

\* It could cause malfunction.



**10.** Do not use the unit for any other purpose than indoor air purification.

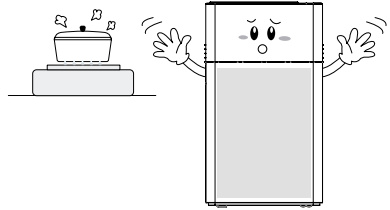

\* if used in the kitchen instead of ventilator, the filter replacement cycle will be shorten.



**11.** Do not unplug the plug and move the purifier while is operating.

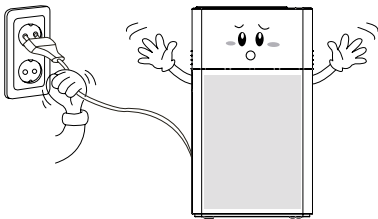

\* It may cause malfunction, wound and damage



**12.** Do not allow children to play on or near the unit.

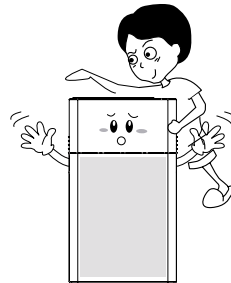

\* Children being supervised not to play with the appliance

## SAFE PLACE FOR INSTALLATION

- Room without the direct sunlight  
It may cause a malfunction
- Do not locate in humid and unventilated room  
It may cause fire and shock
- Keep the distance with any electronic device.  
Electromagnetic from other devices can cause a malfunction.
- Place on flat hard floor  
If not it may cause noise and vibration.  
Place the unit at least 30cm away from the wall.

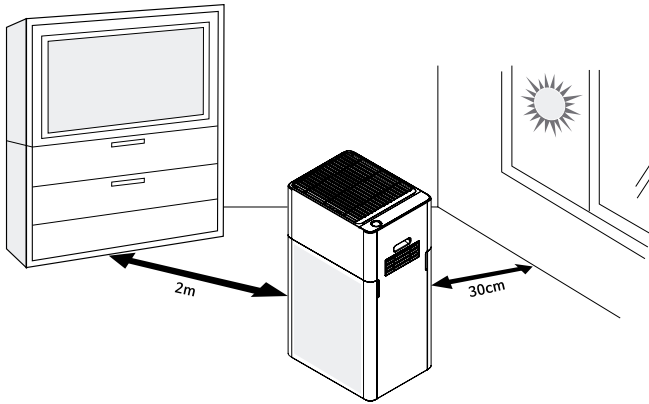

## KNOWLEDGE OF PRODUCT

- Always operate with filters. If you smell the unpleasant smell, please replace the filter.  
This air purifier cannot purify air without filters.  
If the filter is crummy it decrease in performance. The exterior is extremely dirty and smell please replace the filters. Also when the air volume is decreased.
- Do not use the purifier fir reduce odor during cooking.  
This kind of odor will shortens the filters lifepan.  
This kind of odor can be stuck into ultrafine particle free filter. If so please replace the filters.
- While operating purifier, please close the window and door.  
If the window and door is open, the air purifier will be less effective.  
Toxic gas unable to purify: Carbon monoxide (CO)
- Ventilate the room periodicaly.  
When the purifier is operated with dorrs close, the density of carbon dioxide will increase.  
This air purifiers' ventilation alarm is on please turn off the purifier and venitlate the room and restart the purifier. (Purifier cannot purify carbon dioxide)

## 2. NAME OF EACH PART

HORIZON HA 700

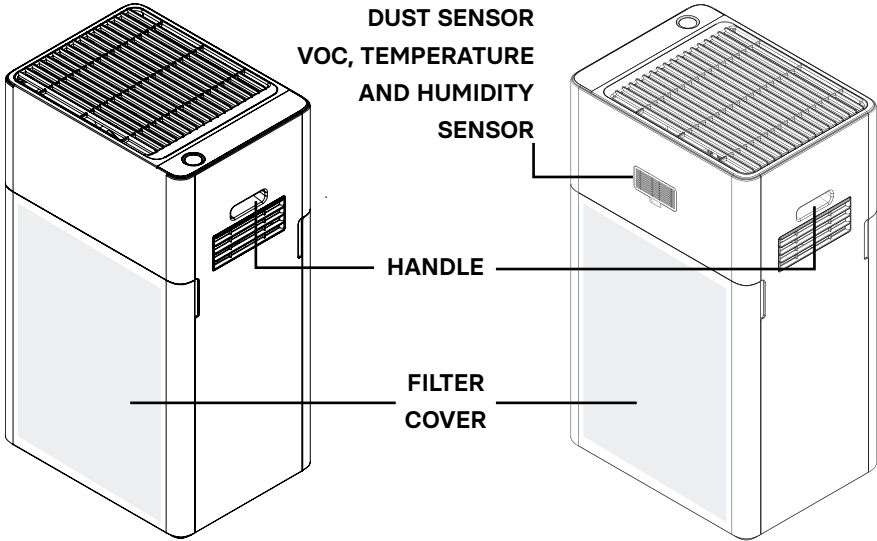

<FRONT SIDE>

<BACK SIDE>

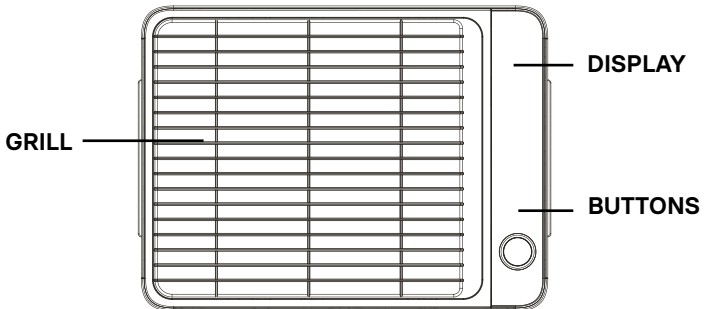

<TOP SIDE >

## 3. CHARACTERISTIC

- **Large capacity purifier**

This purifier capable to purify large applicable area such as office, living room, public place.

- **Simple design**

With simple black and white color design, this purifier can be match with any room.

- **Double side inlet and multi-direction outlet**

Order to have double side inlet filters is attached in both front and back.

- **Four stage of filters**

- Pre-filter: It filters out the big particle dust (ex. hair, pollen...)

- Anti-allergy filter: It filters out influenza and daily odor. Also, deactivate sulfur atom bounding to destroy allergy ingredient.

- Deodorization-filter: It filters formaldehyde and daily odor to keep pleasant environment.

- Ultrafine particle free filter: Filters out the small size particle such as bacteria, tobacco smoke, mold...

- **Dust sensor**

This purifier have dust sensor that can detect the PM2.5 and it display density by number.

- **VOC**

It detect the odorous substance TVOC (TOTAL Volatile Organic Compounds) and send the information and display on connected smart phone.

- **Temperature/humidity sensor**

It detects the temperature and humidity so the user can monitor the condition.

- **Cluster ion generator**

It deploys hydrogen ion (H+) and oxygen ion (O<sup>2-</sup>), combine with moisture and ion form the Cluster ion. Cluster ion forms the OH radical when it combines with the hazardous substance. OH radical has the strong oxidative power, it destroys the hazardous substance.

# 4. CONTROL/SIGNS

**VENTILATION ALARM**  
 VOC sensor detects the density of carbon dioxide if the high concentration of carbon dioxide is detected alarm will activate.

**DISPLAY SWITCH SECTION**  
 Display PM2.5/temperature/humidity (current condition)

**AIR VOLUME DISPLAY SECTION**

**TOTAL POLLUTION INDICATOR**  
 Indicate the total pollution level with 4 different colors by detecting PM2.5 concentration and TVOC concentration.

\*The density of PM2.5 displaying may not be correspond to the color of total pollution level.

\* The total pollution level is displayed based on the worst state of PM2.5 concentration and TVOC.  
 For example, the total pollution is displayed as a bad condition when the PM2.5 concentration is good whereas and TVOC concentration is bad.

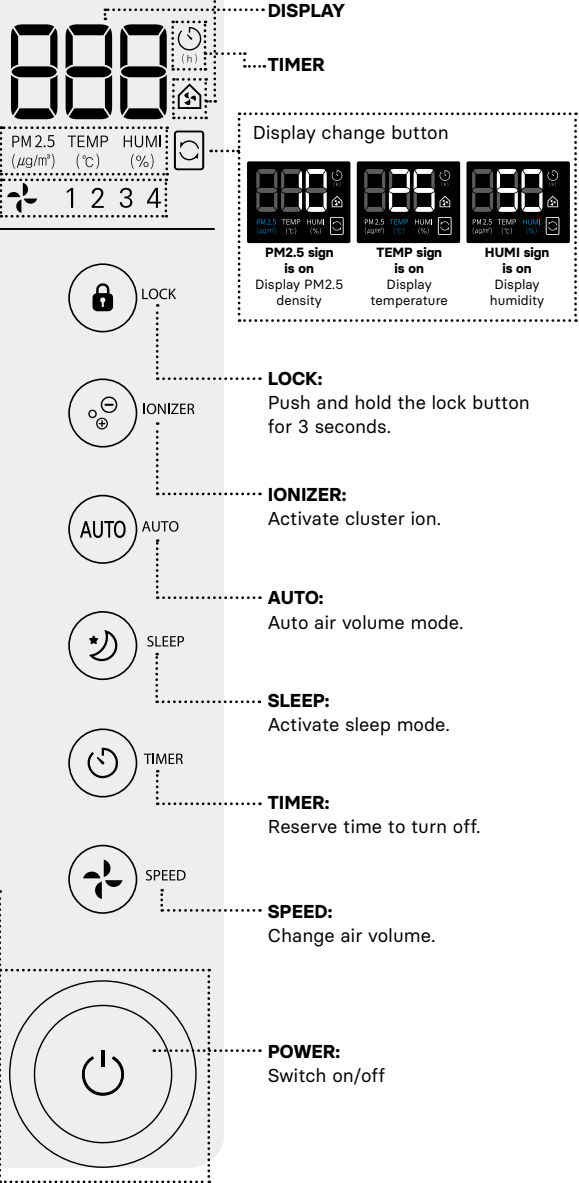

**DISPLAY**

**TIMER**

Display change button

<b>PM2.5 sign is on</b>	<b>TEMP sign is on</b>	<b>HUMI sign is on</b>
Display PM2.5 density	Display temperature	Display humidity

**LOCK**

**LOCK:**  
 Push and hold the lock button for 3 seconds.

**IONIZER**

**IONIZER:**  
 Activate cluster ion.

**AUTO**

**AUTO:**  
 Auto air volume mode.

**SLEEP**

**SLEEP:**  
 Activate sleep mode.

**TIMER**

**TIMER:**  
 Reserve time to turn off.

**SPEED**

**SPEED:**  
 Change air volume.

**POWER**

**POWER:**  
 Switch on/off

## 5. USER INSTRUCTION



**For your safety and proper use of the product, please read and understand the following before use.**

### 1. POWER BUTTON

- It turns on/off the power
- Air purifier will start with buzzer sound.
  - Air volume will set at 1
  - While first 30 second pollution display section color of light change and will reset the Dust/VOC sensor. In this stage, PM2.5 density will not display after 30 seconds total pollution rate and PM2.5 will display on purifier.

### 2. AIR VOLUME BUTTON

- Each time the user push the button air volume will change as this order. stage1 > stage2 > stage3 > stage4 > repeat.
- Current air volume stage will display next to the fan sign by numbers.

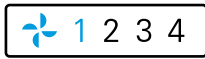

Stage 1



Stage 2

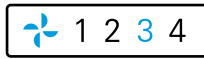

Stage 3

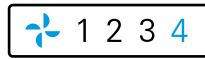

Stage 4

### 3. TIMER BUTTON

- Reserve time to be off. Timer LED light will be on, and it will display set time. Each time user push the button it will change set time in this order. 1H > 2H > 4H > 8H > 12H > OFF > repeat.
- When the timer is set the set time will display after 10 second, also user can check the set up with timer LED light.
- Purifier will turn off after set a time.

### 4. SLEEP MODE

- It set the sleep mode. Air volume will decrease less than stage1, display light will get dimmer, and buttons' buzzer sound will be off.
- Re-push the button will deactivate the sleep mode.
- Can use the timer during sleep mode by just pushing a timer button.

### 5. AUTO BUTTON

- It set the automatic air volume mode. It automatically changes the air volume by comprehensive data from the VOC sensor and Dust sensor.
- It activate with 3 stages.  
Good (blue) - stage1, Normal (green) - stage2, Bad (yellow)/Very bad (red) - stage 3.

### 6. ION BUTTON

- It activates the cluster ion generator, ion sign will lit up.

## 5. USER INSTRUCTION

### 7. LOCK BUTTON

- It activates lock mode. Lock sign will lit up, the buzzer will sound.
- When the lock mode is on, other functions button will not function.

### 8. DISPLAY CHANGE BUTTON

- Each time the user pushes this button display will change as this order.  
PM2.5 density > temperature > humidity > repeat.
- PM2.5 volume: 5~999 $\mu\text{g}/\text{m}^3$  displayable.
- Temperature: 0~100°C displayable
- Humidity (relative humidity): 0~100% RH displayable.

# RATE OF ULTRAFINE DUST

## What is PM2.5?

Dust particle size is less than 2.5µm. According to research, smaller particle affects the human health. So all the developed countries instructed since the late 90's.

Since July 2017 Republic of Korea change environment standard; 15µg/m<sup>3</sup> yearly to 35µg/m<sup>3</sup> daily.

- The density of PM2.5 start with 5 till 999 display single decibel.
- The density rate of PM2.5 is informed from the sensor manufacturer database.
- The stage of PM2.5 density is informed from the minister of environment PM2.5 forecast.
- The stage of PM2.5 density informed by a PM2.5 forecast from the minister of environment.
- The density of PM2.5 can differ indoor and outdoor.
- HORIZON air purifier's rate of PM2.5 a density might differ than other brands air purifier's and measuring instrument.
- The rate of PM2.5 density can be affected by surrounding and air flow.
- The rate of PM2.5 density can be affected by environment (Roadside, factory, construction site)
- The dust storm, a PM2.5 alert is activated air is keep came from outside, the rate of density might continuously increase.

## What is TVOC

VOC (Volatile Organic Compounds) is gas of liquid organic compound evaporates at a low temperature. VOC and Nitrogen oxide photochemical reaction occurs it produces ozone and photochemical oxidant. It is carcinogenicity particle similar to photochemical smog, benzene extremely harmful to the human body. Also, styrene and most VOC classified as particle cause stink odor.

TVOC (Total Volatile Organic Compound) is named all kind of VOC gases, its used as a guideline for Environmental diagnosis.

- VOC and CO2 density measures might differ from real measures. About 5 minutes after Power is on.
- Products occur odor such as perfume, air freshener, detergent might effect TVOC measures, do not place the purifier for long time place occurs odor.
- If the sensor close to the product occurs odor might display the total pollution level continuously high.
- HORIZON air purifier follows German Federal Environment Agency's TVOC pollution rate lighting colors. (The Republic of Korea do not have any guideline)



# 6. HOW TO REPLACE THE FILTER

## PRECAUTIONS ON USING FILTER

### 1. Precautions for using filters

- Make sure to use Wonbong genuine filters.
- Contact service center to purchase filter.
- Please follow the instruction for replacing filter.

### 2. Precautions for replacing filter.

- Make sure to disconnect the power cord before replacement.
- Make sure to remove vinyl of the new filter. If you use the air purifier with the filter covered by vinyl, a warpage or a fire could happen due to the unusual sound and overheating of the motor.
- No returns are allowed if you remove the packing of the set of the new filter.

## FEATURES OF FILTER

### 1. Pre filter

Traps large particles in the air such as dust, fur, pollen, and so on.

### 2. Anti-allergy filter

It filters out influenza and daily odor. Also, deactivate Sulfur atom bonding to destroy allergy ingredient.

### 3. Deodorization-filter

It filters formaldehyde and daily odor to keep pleasant environment

### 4. Ultrafine particle free filter

It filters out the small size particle (0.3um) such as bacteria, tobacco smoke, mold, and etc...

## FILTER LIFESPAN

	1 STAGE	2 STAGE	3 STAGE	4 STAGE
FILTER	Pre-filter	Anti-allergy filter	Deodorization filter	Ultrafine particle free filter
TIME FOR CHANGE	Semi-permanent	About a 4 month	About a year	About an 8 month
CLEANING	Clean with water (once a month)	Cannot be clean Change the filter	Cannot be clean Change the filter	Cannot be clean Change the filter

## 6. HOW TO REPLACE THE FILTER

1. After unplug the plug pull it off the front and back filter cover.

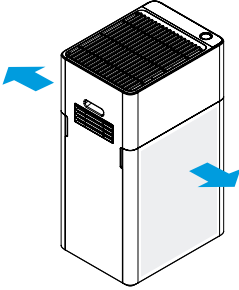

2. After removes pre-filter grab a filter handle and pull it off.

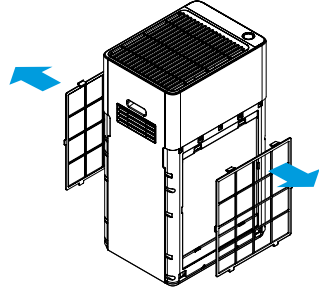

3. Re-use the pre-filter after clearly washed with water and fully dry under the shade.

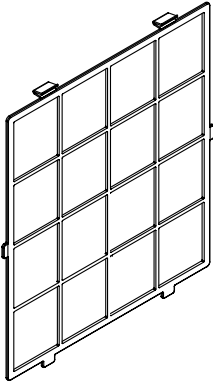

4. Insert the new filter in the order.

- From inside: 1. Ultrafine particle free filter. 2. De-odor filter.
- 3. Anti-allergy filter. 4. Pre-filter.
- Please follow the insert direction on side of Ultrafine particle free filter.

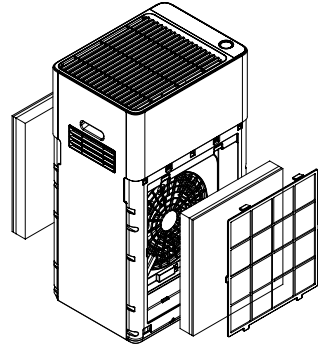

5. Attach the pre-filter

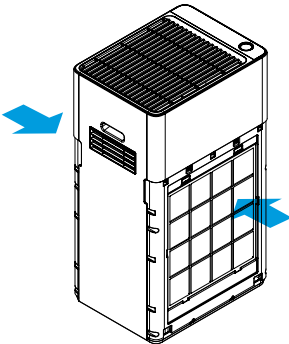

6. Attach the filter cover.

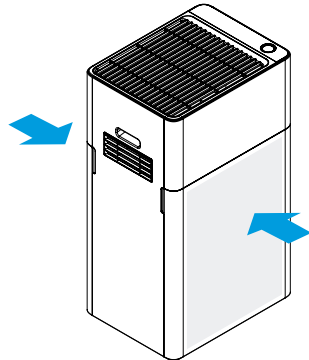

## 7. HOW TO CLEAN PRE-FILTER

- Every once a month the pre-filter carefully with water.
- Do not use benzene, alcohol, volatility detergent and hot water (over 40°C) It causes the damages and discoloration.
- The term of cleaning can be change by usage and surronud air quality.

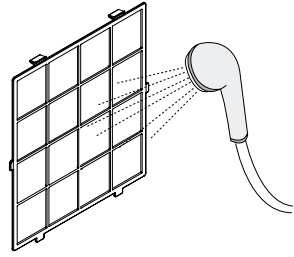

## HOW TO CLEAN EXTERIOR

- Wipe with dry cloth.
- Every once or twice a month clean the back and front filter covers with dust cleaner or vacuum.
- Do not use benzene, alcohol, volatility detergent and hot water (over 40°C) It causes the damages and discoloration.
- Do not use water, thinner or any volatility liquid.

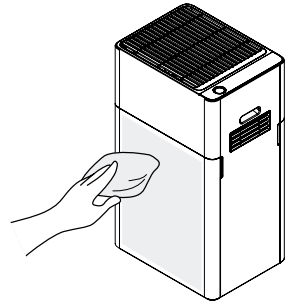

## HOW TO CLEAN DUST SENSOR

- Unplug the cord before cleaning.
- Open the dust sensor cover and carefully wipe the lens with Q-tip.
- If the foregin partials (such as dust) is around the sensor, the rate of pollution might get disrupt.
- Clean the dust sensor every 6 month. Cleaning term can be change by pollution and amount of use.

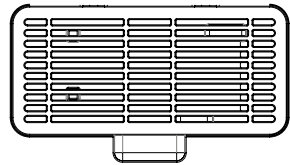

## 8. SOLUTION TO COMMON PROBLEMS

Check the list below before report failure.

If still causing a trouble after following the list below please contact Service center of Retail store.

ISSUE	CAUSE	SOLUTION
<b>The purifier is not working</b>	Is it power plug fully plugged?	Re-plug the power plug correctly
	Is it blackout?	Check the power state
	Is it filter cover is not attached?	Attach the filter cover correctly
<b>AUTO mode doesn't work.</b>	Is it power plug is fully plugged?	Plug the power plug correctly
	Di you select the AUTO mode?	Push the air volume button to select AUTO mode
<b>Total pollution level sign is kept lighting red</b>	Did you clean the sensor?	Clean the dust sensor.
	Is something causing odor near purifier?	Relocate the purifier. If still causing a trouble please contact the service center.
<b>Making a loud noise and vibrate</b>	Is it located on an uneven floor?	Relocate the purifier on the evenly flat floor. (All the legs need to touch the floor)
<b>Power plug and the power outlet is overheating</b>	Is it power plug is fully plugged?	Re-plug the power plug correctly
<b>Funny smell</b>	Is it any smoke and smelly substances is rounq?	Clean the pre-filter and change the other filter.
<b>Is not purifying the air</b>	Is it compacted with dust or air outlet is a block with any objects.	Clear off the objects on the outlet
<b>Unusual sign</b>	Specific sign part is lighting up and makes "Ding Ding" sound	Attach the filter cover correctly. If it kept making sound please contact customer service.
<b>Unusual sound</b>	It makes scratching noise	When the culster ion generator is operating it makes the scratching noise.

## 9. SPECIFICATIONS

- PRODUCT NAME: HORIZON air purifier
- MODEL: HA700
- POWER RATING: 220-240V/50Hz
- SIZE: 440(W)x 330(D)x 767,5(H) mm
- WEIGHT: About 14kg
- POWER CONSUMPTION: 68W

## 10. WARRANTY

PRODUCT

DATE OF MANUFACTURE

DATE OF PURCHASE

CUSTOMER'S NAME

DEALER'S NAME

### WARRANTY GUIDE

1. The warranty period is 12 months from date of purchase.
2. The product will be repaired at cost in following cases:
  - After expiry of free warranty period
  - Malfunction of the unit caused by careless or abnormal use
  - Malfunction of the unit caused by natural disaster
  - In case of lost of this manual

## NOTES

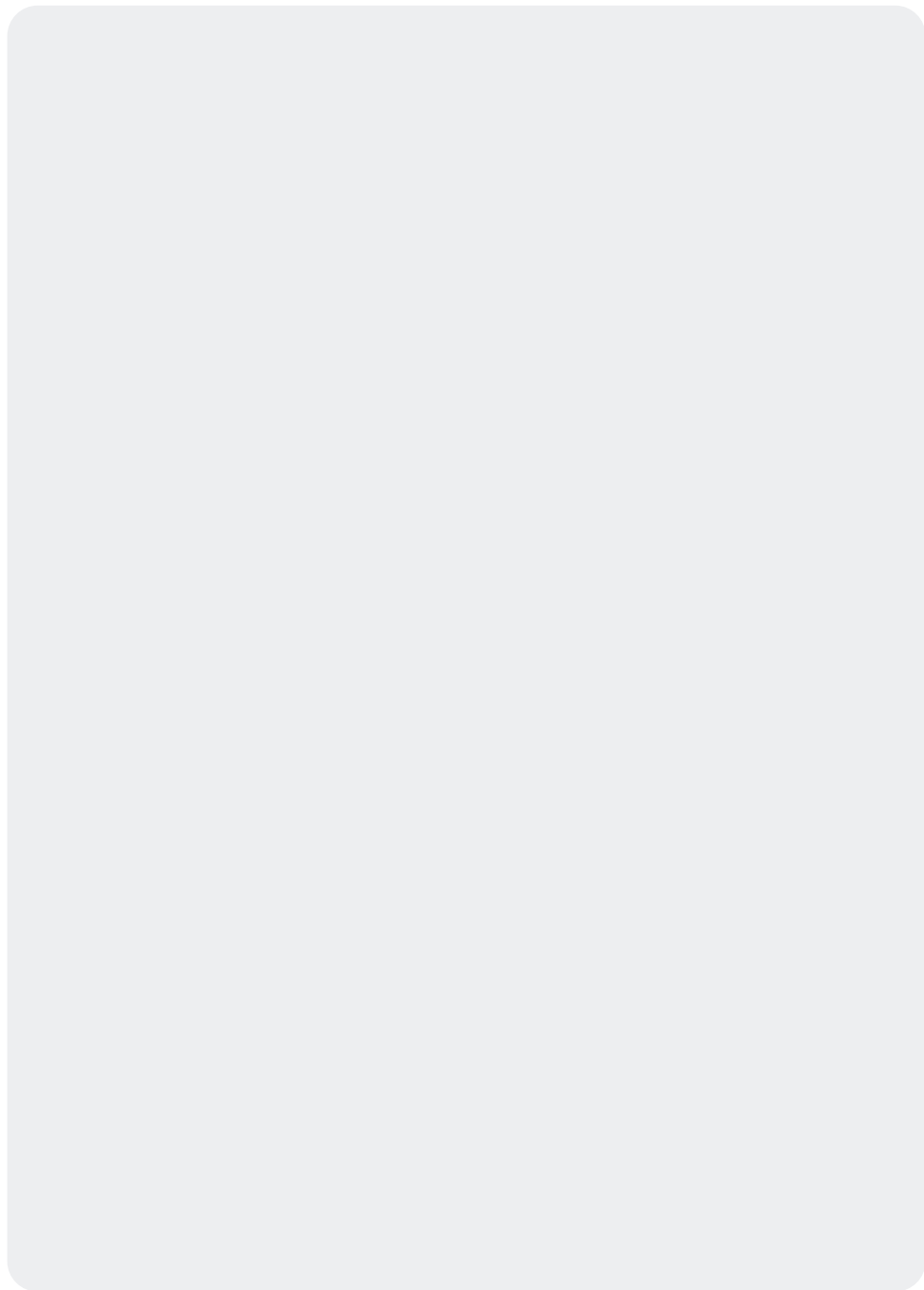

# HA 700

Air purifier

horizon

A I R P U R I F I E R